



5 axis clamp tool revolution



Grip Center Clamp Series	02 - 09
Grip Type Tooth Pre-Bite Machine	10
Grip Center Clamp Series	11 - 12
Quick Change Plate	13 - 14
Quick Change Adapter Plate 52P to 96P	15
Quick Change Plate	16 - 17
Origin Clamp System	24
Machine Arm Chuck	25
Machine Arm Collet Accessories	26

“WEI” means we pay attention to every detail of the making process, and “ZHUN” means falcon bird, which can fly fast, also a good hunter of nature. We set high demand to our company that we should be deliberate to every production detail carefully for perfection through the manufacturing process. We request our product quality should be stable, the quality management and dimensional requirements must be practicable. We expect ourselves work as efficiently as Falcone birds, also, we hope that we can make more accurate and greater products in the future.

Accurate Positioning

Fast Exchange

Flexibility

PAT. China / German / Japan / Taiwan / U.S.A.



Grip Center Clamp Series

2" Self-Centering Vises



Technical Data	A	B	C	L	E	F	Clamping Range	Clamping Force	Torque
----------------	---	---	---	---	---	---	----------------	----------------	--------

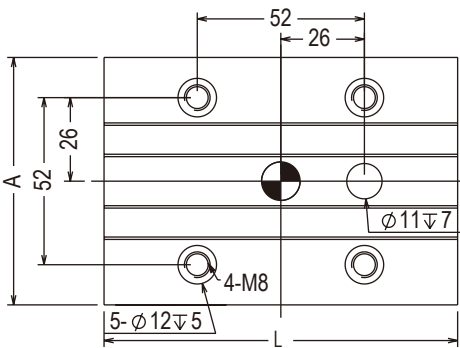
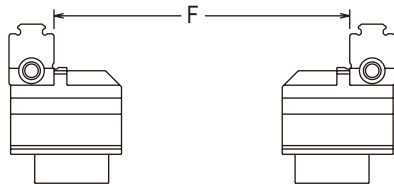
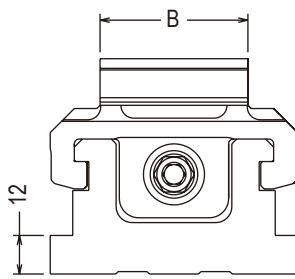
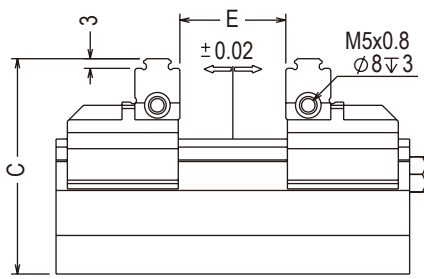

Technical Data	A	B	C	L	E	F	Clamping Range	Clamping Force	Torque
2" Self-Centering Vise WEV-2AS090	77	46	67	110	0-50	43-90	13kN/60Nm	Max.70Nm	2.5
2" Large Self-Centering Vise WEV-2AL200	77	46	67	220	0-150	43-200	13kN/60Nm	Max.70Nm	4.1

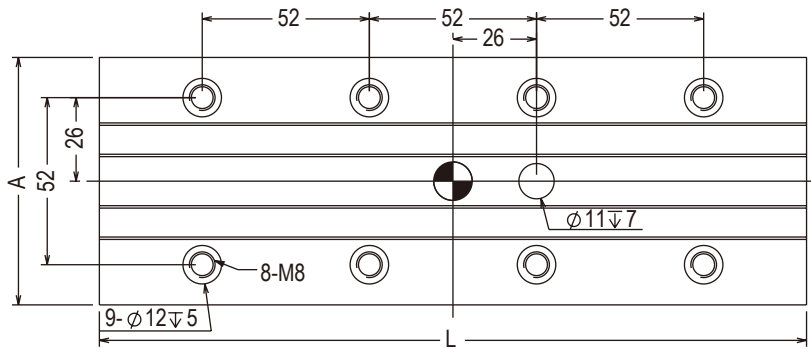

2AS Back View



2AL Back View

Attachment	Recommended
Tool = 6mm	Max. 70Nm
	

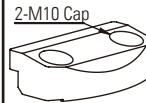
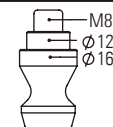
Optional Accessories	
WEV-0300	WEV-0316
	
1 set of 2	1 set of 4

Grip Center Clamp Series

3" Self-Centering Vises



	Technical Data	A	B	C	L	E	F	Clamping Range	Clamping Force	Torque	Set/Kg
3" Self-Centering Vise	WEV-3AS090	77	77	67	110	0-50	43-90	13kN/60Nm	Max.70Nm	2.6	
3" Large Self-Centering Vise	WEV-3AL200	77	77	67	220	0-150	43-200	13kN/60Nm	Max.70Nm	4.2	

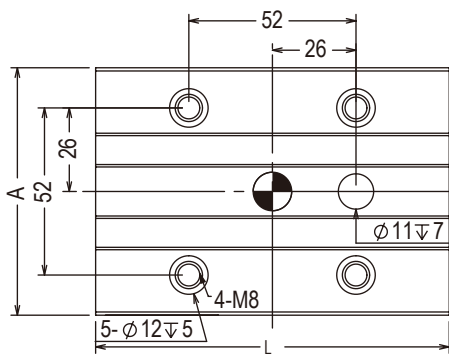
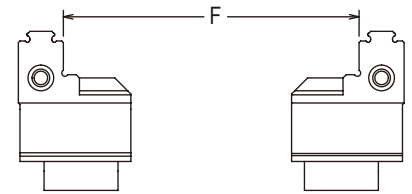
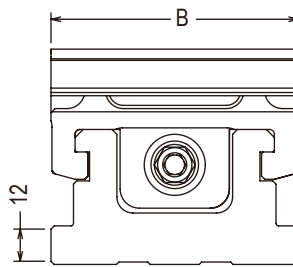
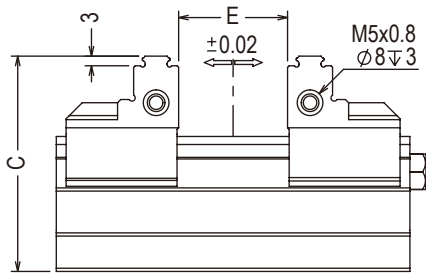

3AS Back View

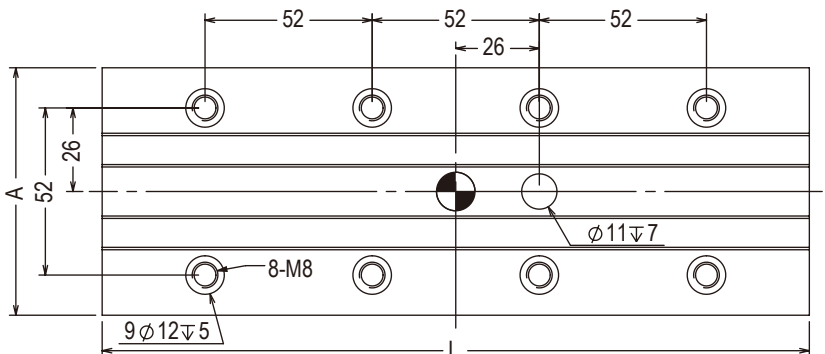

3AL Back View

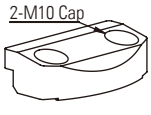
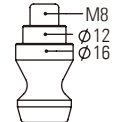
Optional Accessories	
WEV-0300	WEV-0316
 <p>2-M10 Cap</p>	 <p>M8 Ø12 Ø16</p>
1 set of 2	1 set of 4

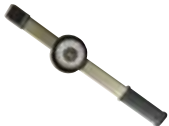
Attachment	Recommended
 <p>Tool = 6mm</p>	 <p>Max. 70Nm</p>

Grip Center Clamp Series

3" Double Station Vises

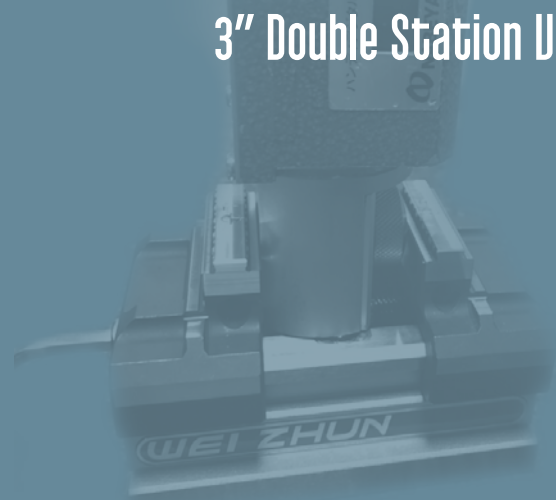
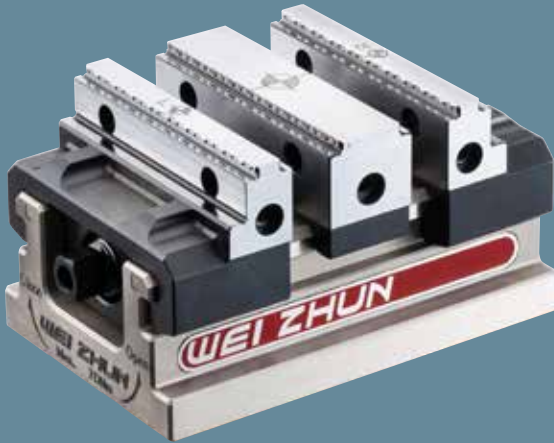

	Technical Data	A	B	C	L	Clamping Range	Clamping Force	Torque	Vise Assembly Set/Kg	
3" Double Station Vise	WEV-3BS040	77	77	67	120	0-22	44-40	13kN/60Nm	Max.70Nm	3.2
3" Large Double Station Vise	WEV-3BL090	77	77	67	220	0-65	22-90	13kN/60Nm	Max.70Nm	4.6

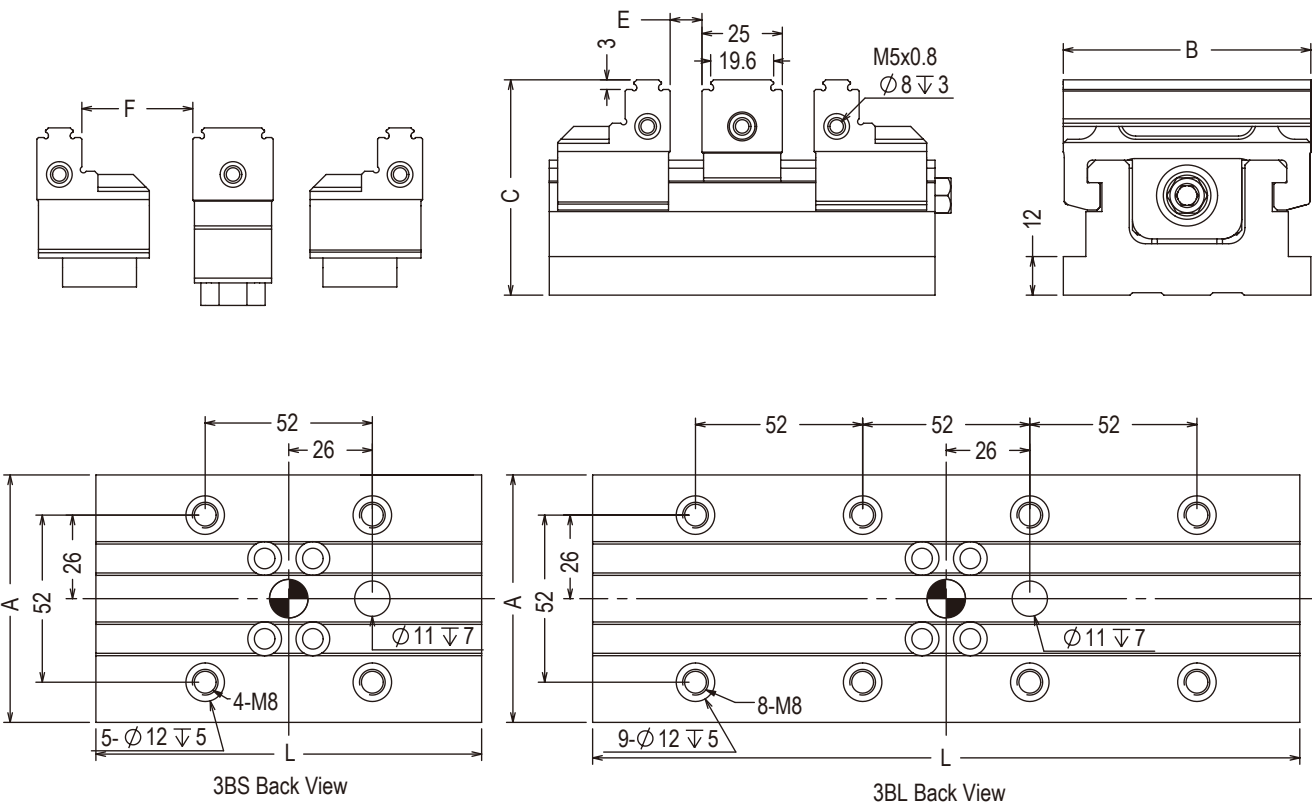

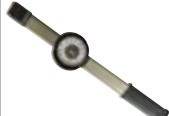
Attachment		Recommended	
Tool = 6mm		Max. 70Nm	
			

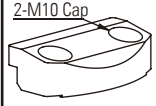
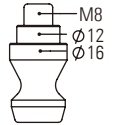
Optional Accessories	
WEV-0300	WEV-0316
	
1 set of 2	1 set of 4

Grip Center Clamp Series

5" Self-Centering Vises



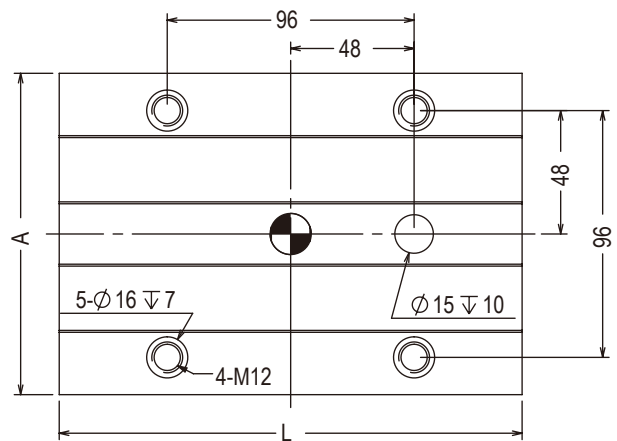
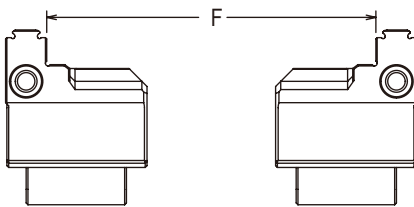
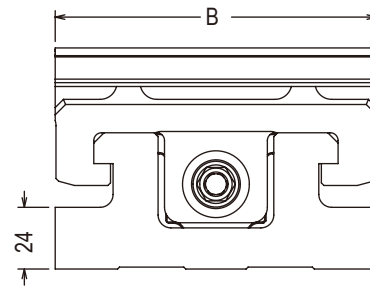
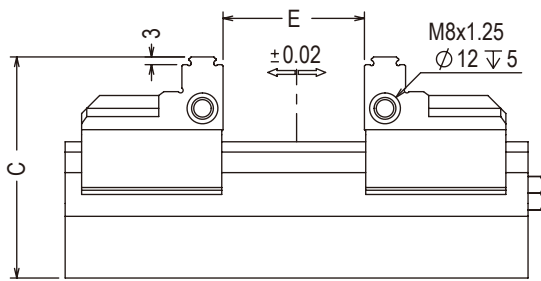

	Technical Data	A	B	C	L	E	F	Clamping Range	Clamping Force	Torque
									Vise Assembly	Set/Kg
5" Self-Centering Vise	WEV-5AS155	125	125	86	180	0-90	80-155	15.6kN/85Nm	Max.100Nm	9.0
5" Large Self-Centering Vise	WEV-5AL205	125	125	86	230	0-140	80-205	15.6kN/85Nm	Max.100Nm	10.6

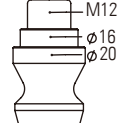

5AS 5AL Back View

Optional Accessories	
WEV-0500	WEV-0520
	
1 set of 4	1 set of 4

Attachment	Recommended
Tool = 8mm	Max. 100Nm
	

Grip Center Clamp Series

5" Double Station Vises



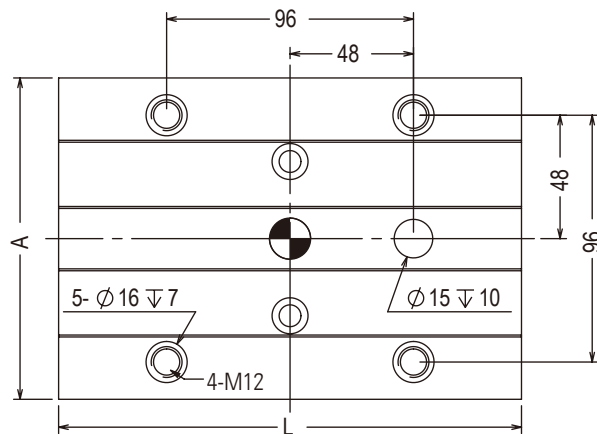
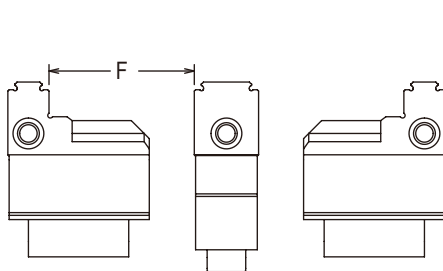
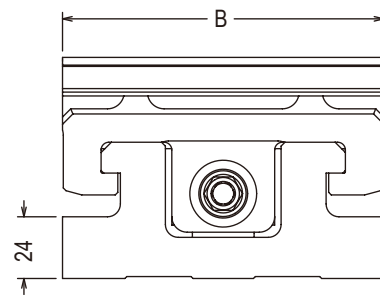
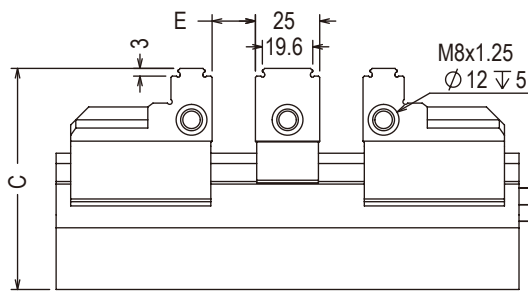

	Technical Data	A	B	C	L	E	F	Clamping Range	Clamping Force	Torque
									Visse Assembly	Set/Kg

5" Double Station Vise	WEV-5BS070	125	125	86	180	0-40	40-70	15.6kN/85Nm	Max.100Nm	9.8
5" Large Double Station Vise	WEV-5BL090	125	125	86	230	0-57	40-90	15.6kN/85Nm	Max.100Nm	11.4



5BS 5BL Back View

Attachment	Recommended
Tool = 8mm	Max. 100Nm
	

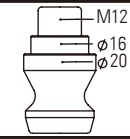
Optional Accessories	
WEV-0500	WEV-0520
	
1 set of 4	1 set of 4

Grip Center Clamp Series



5" Grip Vises

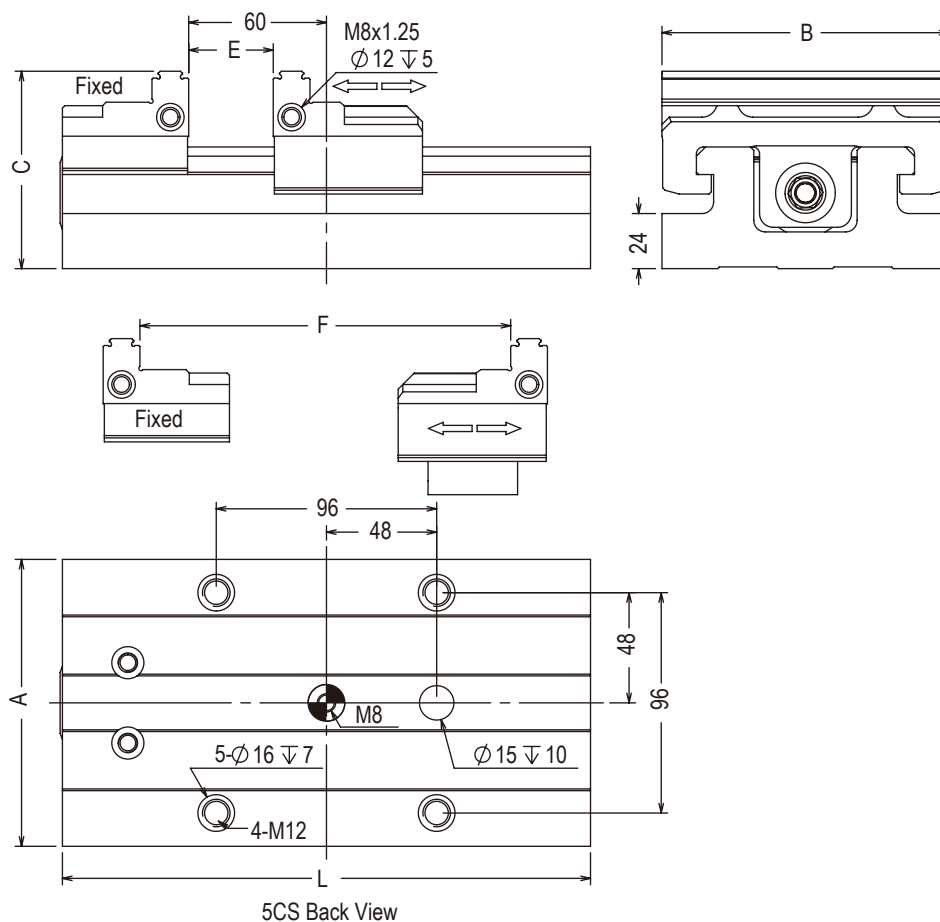

	Technical Data	Clamping Range						Clamping Force	Torque	Vise Assembly Set/Kg
		A	B	C	L	E	F			
5" Grip Vise	WEV-5CS200	125	125	86	230	0-115	90-200	15.6kN/85Nm	Max.100Nm	10.6

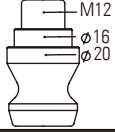

Optional Accessories	
WEV-0500	WEV-0520
	
1 set of 4	1 set of 4

Attachment	Recommended
Tool = 8mm	Max. 100Nm
	

Grip Center Clamp Series

3" Self-Centering Vises

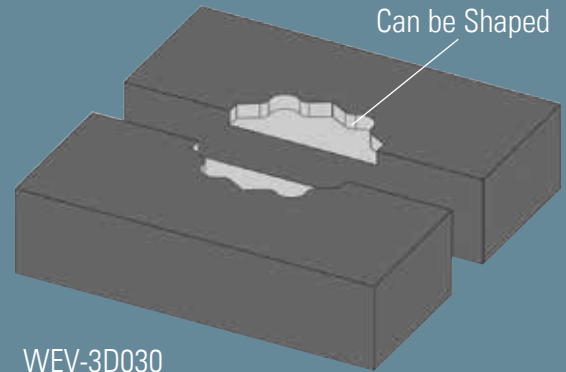

WEV-3D030

	Technical Data	A	B	C	L	E	Clamping Range	Clamping Force	Torque	Set/Kg	
3" Self-Centering Vise	WEV-3DS110	77	112	59	110	125		13kN/60Nm	Max.70Nm	3.1	
3" Large Self-Centering Vise	WEV-3DL220	77	112	59	220	235		13kN/60Nm	Max.70Nm	4.7	
	Technical Data	A	B	C	D	E	F	G	T	Material	Set/Kg
3" Soft Jaws	WEV-3D030	122	50	30	112	40	92	24	M8	S50C	2.5

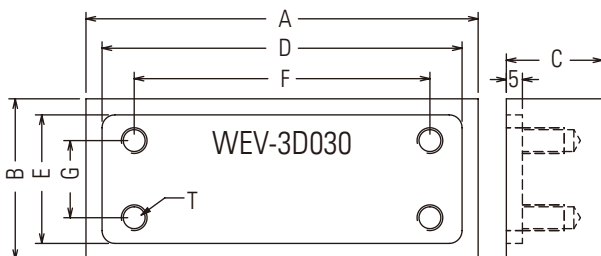
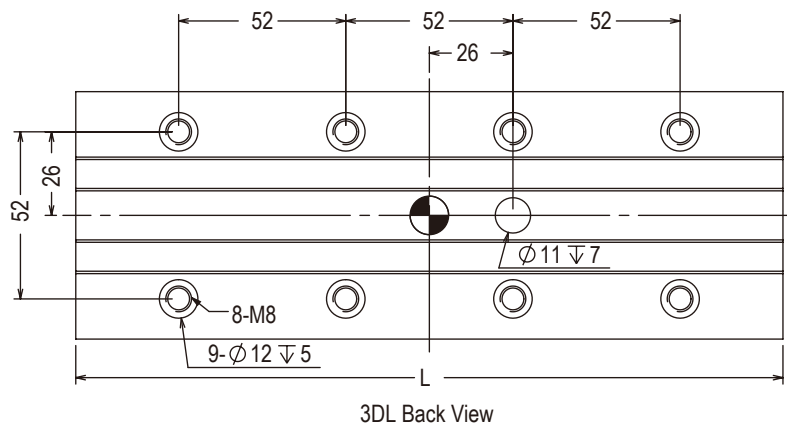
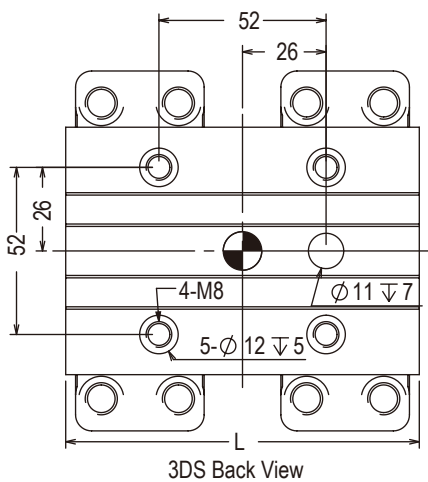
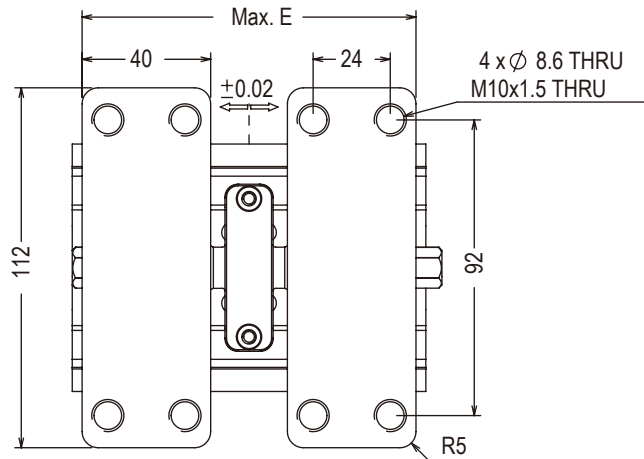
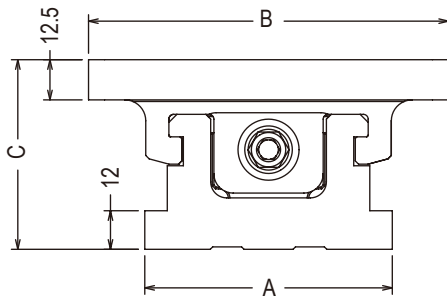

Attachment	Recommended
Tool = 6mm	Max. 70Nm

Optional Accessories	
WEV-0300	WEV-0316
1 set of 2	1 set of 4

Grip Center Clamp Series

5" Self-Centering Vises

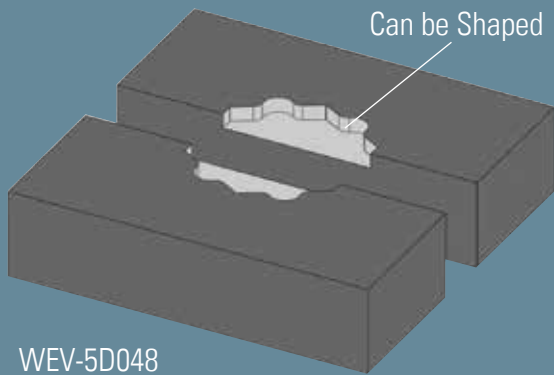

WEV-5D048



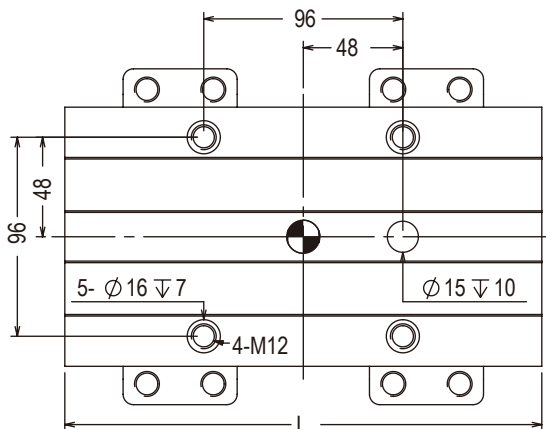
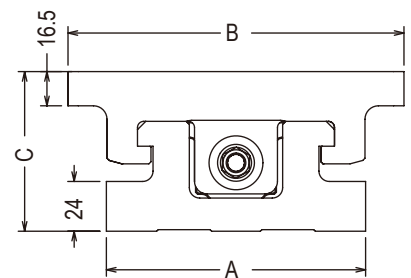
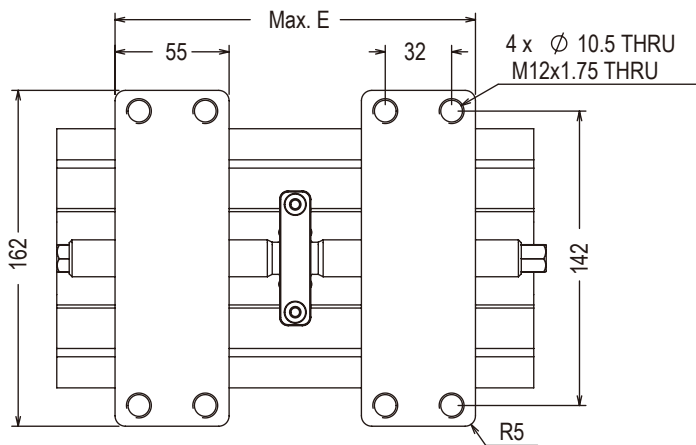

	Technical Data	A	B	C	L	Clamping Range	Clamping Force	Torque	Set/Kg		
5" Self-Centering Vise	WEV-5DL230	125	162	77	230	E	15.6kN/85Nm	Max.100Nm	11.4		
	Technical Data	A	B	C	D	E	F	G	T	Material	Set/Kg
5" Soft Jaws	WEV-5D048	172	65	48	162	55	142	32	M10	S50C	7.6

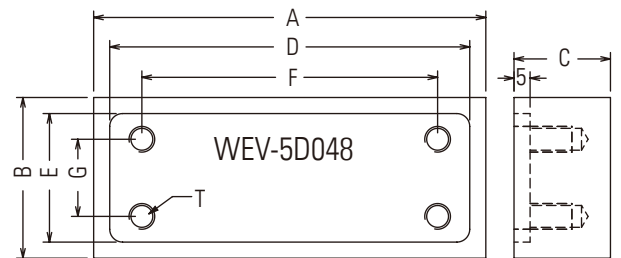

5DL Back View

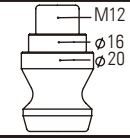

Optional Accessories	
WEV-0500	WEV-0520
	
1 set of 4	1 set of 4

Attachment	Recommended
Tool = 8mm	Max. 100Nm
	

Grip Type Tooth Pre-Bite Machine



WEV-5PB210

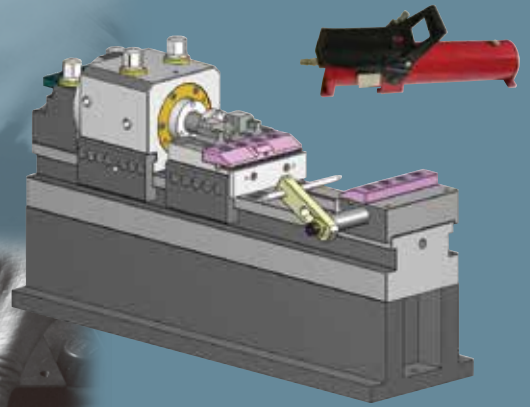

WEV-5PB210-A

	Technical Data	L	W	H	Clamping Range	Clamping Force	Compressed Air	Set/Kg
Grip Type tooth Pre-Bite Machine	WEV-5PB210	950	600	1050	210mm	HRC 38°	6-10 Bar	215
Grip Type tooth Pre-Bite Machine	WEV-5PB210-A	615	175	345	210mm	HRC 38°	6-10 Bar	117

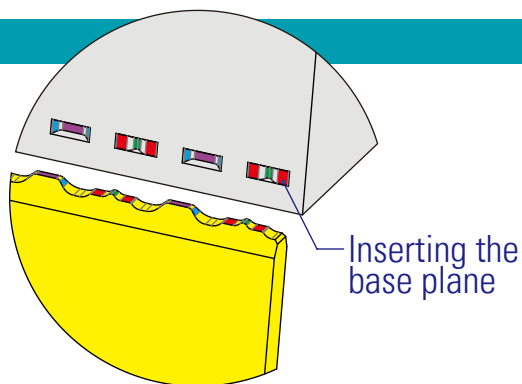
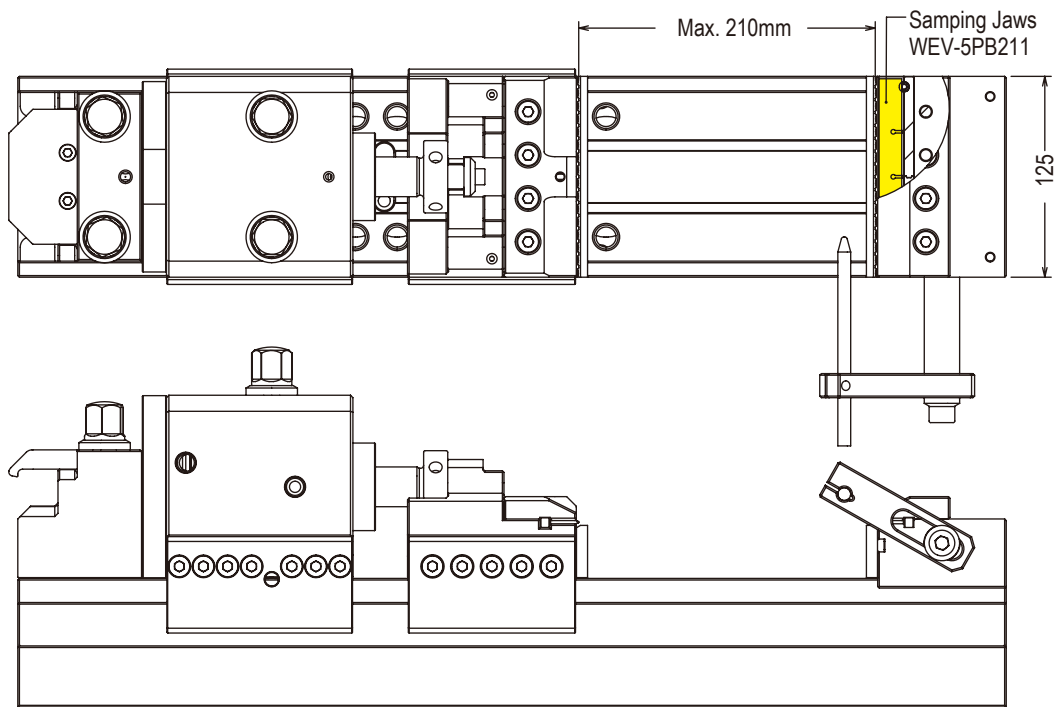

	Technical Data	Quantity	Set/Kg
Sampling Jaws	WEV-5PB211	1 Set of 2	0.07

Grip Center Clamp Series

3" Installation Diagram

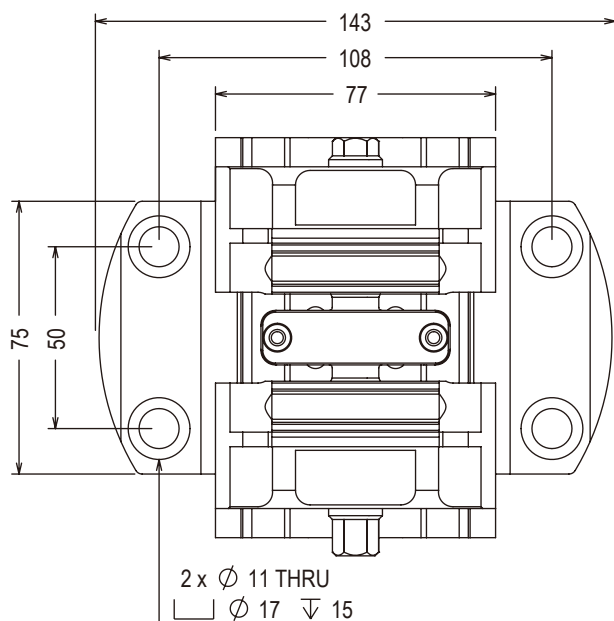

5" Installation Diagram

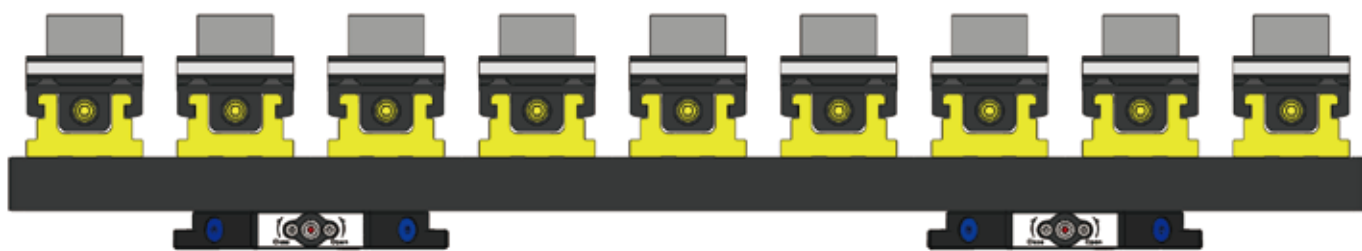
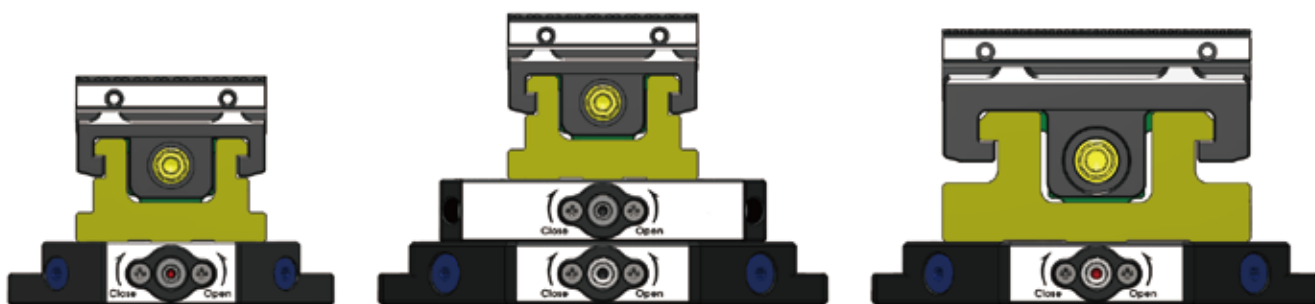
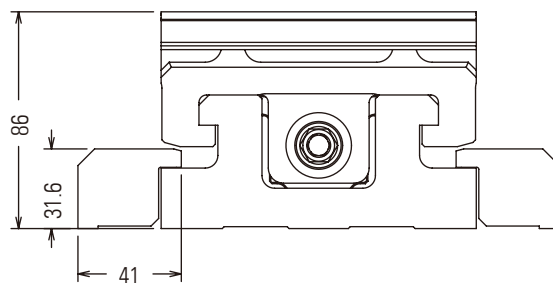
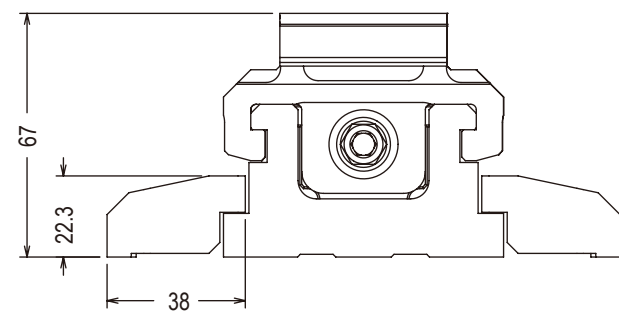
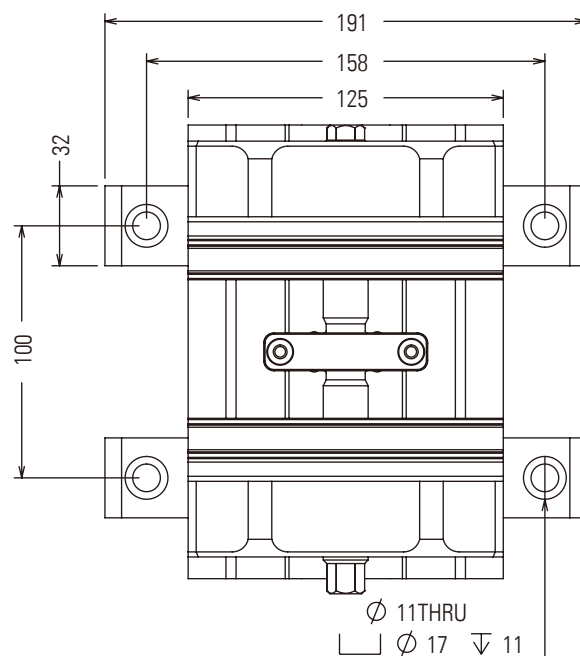

Grip Center Clamp Series

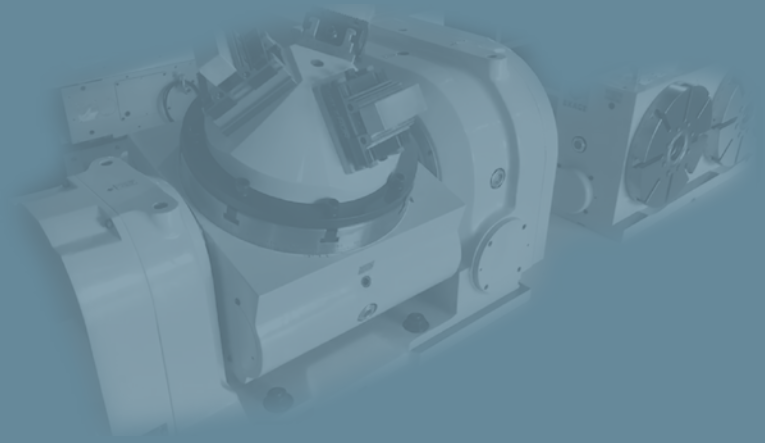

Technical Data	Dimensions	Set/Kg
WEV-3P315	Ø315 x 130mm	22.6

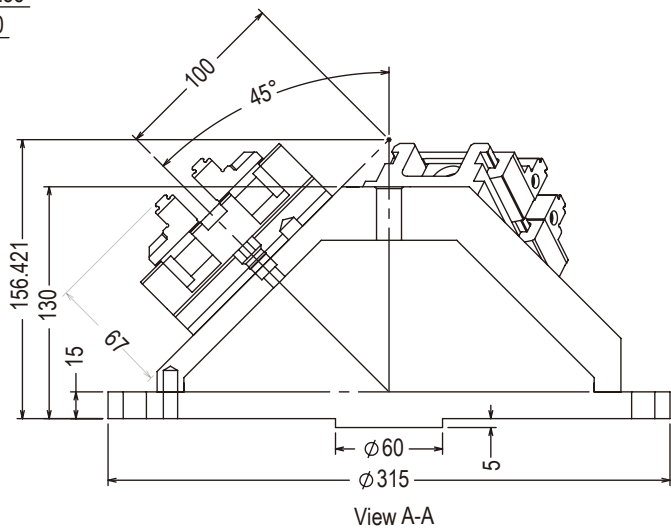
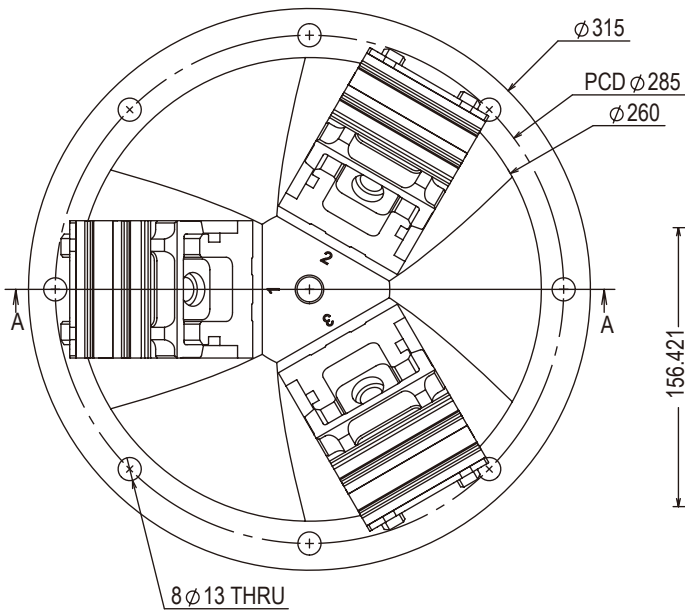

WEV-3016 Pull Studs (52P)

1 set of 4 pcs 0.12kg/set

WEV-0520 Pull Studs (96P)

1 set of 4 pcs 0.21kg/set

Quick Change Plate



Quick Change Plate-52P	Technical Data	Dimensions	Clamping			Set/Kg
			Force	Repeatability	Recommended	
WE-270300	25.4x132x132mm	15000N	0.005mm	Max.25Nm	2.0	

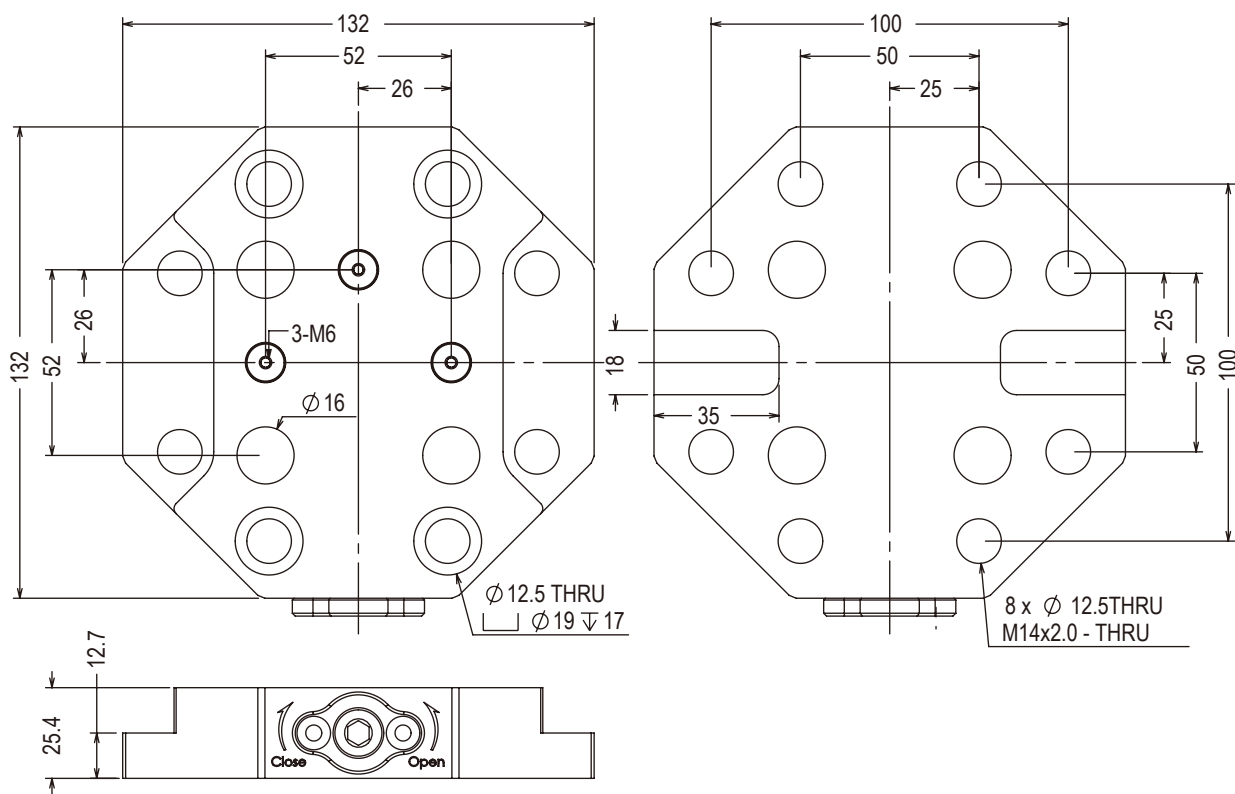

Optional Accessories
WEV-0316
1 set of 4

Attachment	Recommended
Tool = 6mm	Max. 25Nm

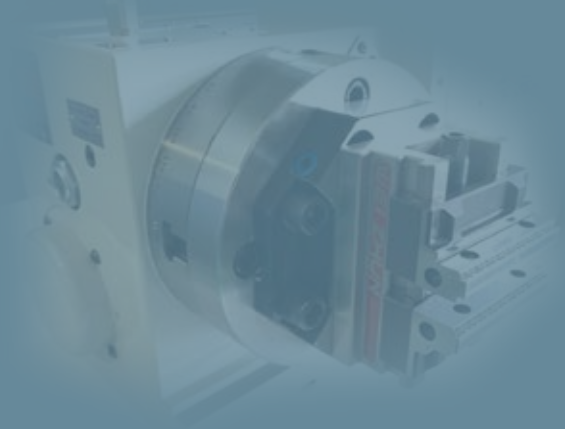

Quick Change Plate

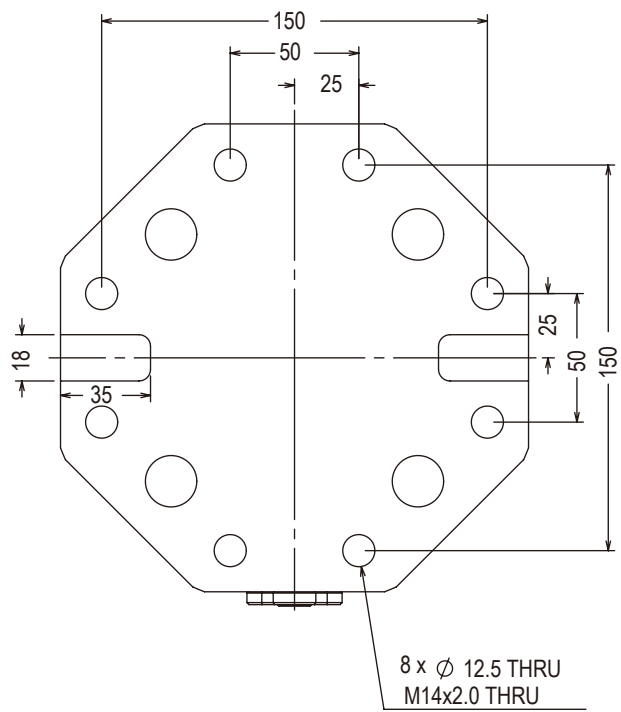
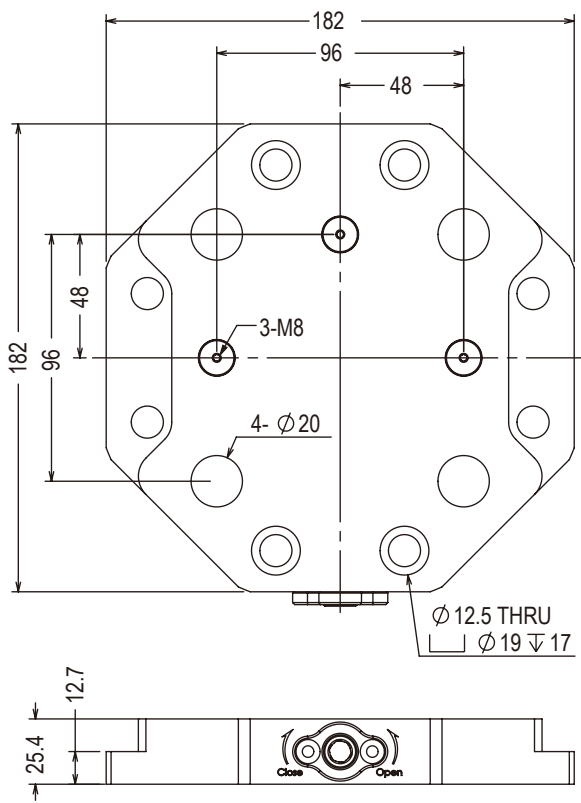

Clamping

	Technical Data	Dimensions	Force	Repeatability	Recommended	Set/Kg
Quick Change Plate-96P	WE-260500	25.4x182x182mm	15000N	0.005mm	Max.30Nm	4.3

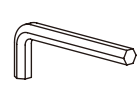

Attachment	Recommended
Tool = 8mm	Max. 30Nm
	

Optional Accessories

WEV-0520

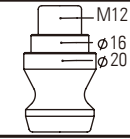

1 set of 4

Quick Change Adapter Plate 52P to 96P



Clamping

	Technical Data	Dimensions	Force	Repeatability	Recommended	Set/Kg
Quick Change Adapter Plate	WE-280000	25.4x132x132mm	15000N	0.005mm	Max.25Nm	3.0

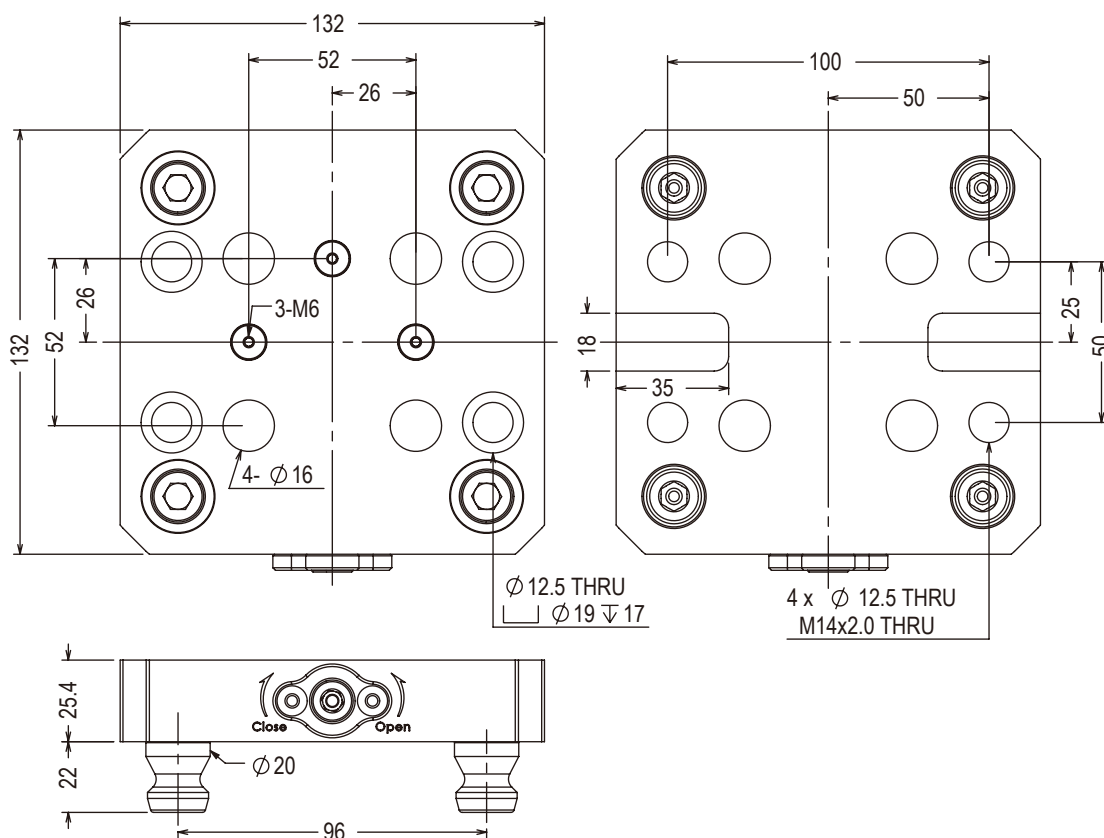

Optional Accessories
WEV-0316
1 set of 4

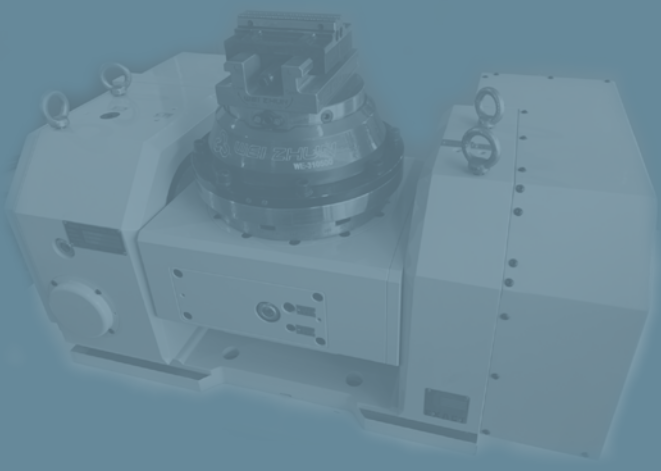

Attachment	Recommended
Tool = 6mm	Max. 25Nm

Quick Change Plate

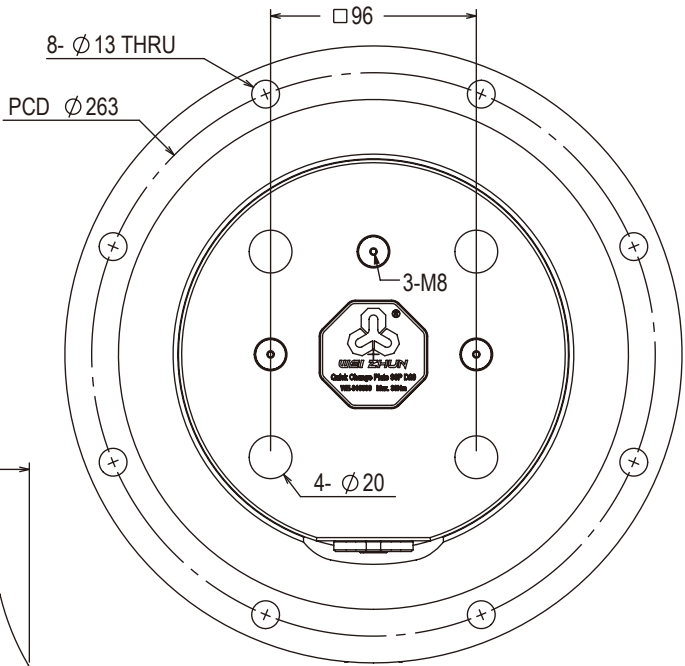
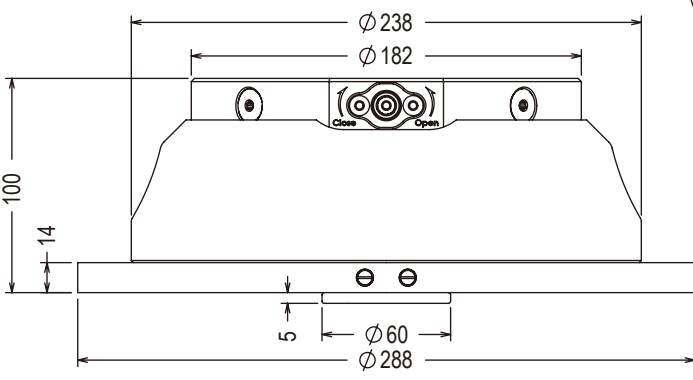

	Technical Data	Dimensions	Clamping Force	Repeatability	Recommended	Set/Kg
Quick Change Plate-96P	WE-310500	Ø288x100mm	15000N	0.005mm	Max.30Nm	17.0

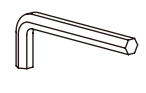

Attachment	Recommended
Tool = 8mm	Max. 30Nm
	

Optional Accessories

WEV-0520

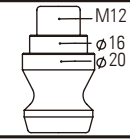

1 set of 4

Quick Change Plate

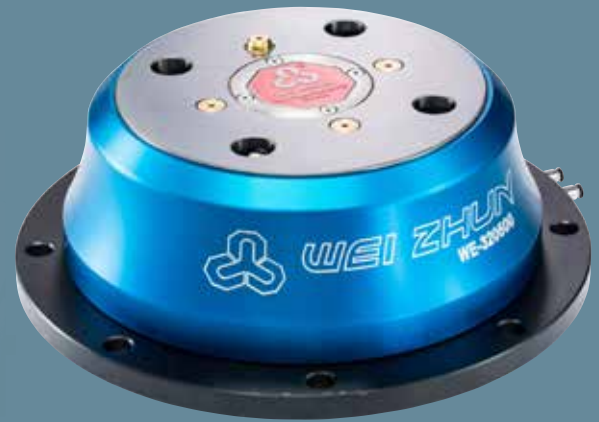

	Technical Data	Dimensions	Clamping Force	Repeatability	Compressed Air	Set/Kg
Quick Change Plate-96P	WE-320500	Ø288x100mm	15000N	0.005mm	6-10 Bar	19.0

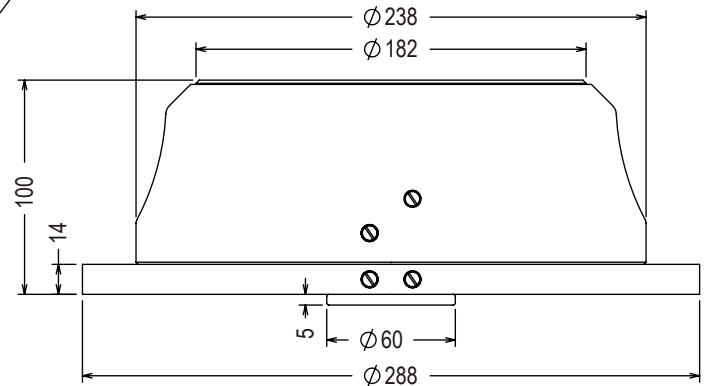
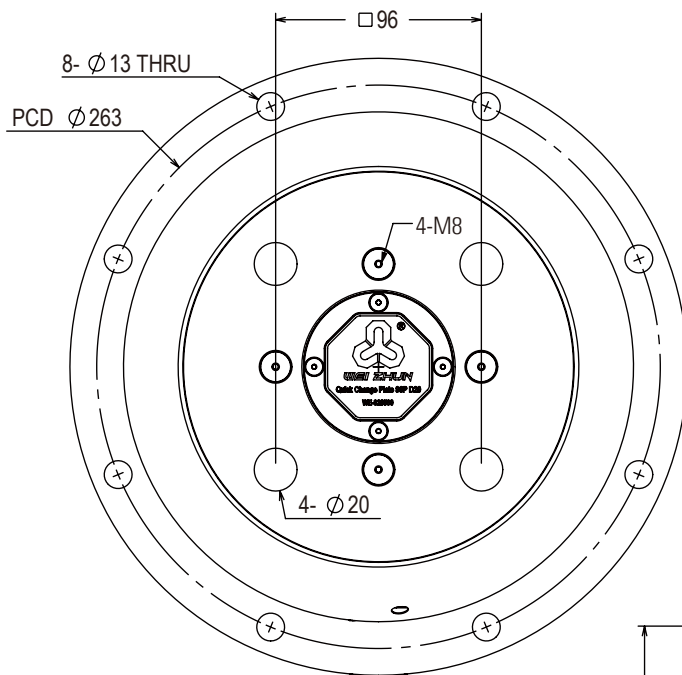

Optional Accessories
WEV-0520
1 set of 4

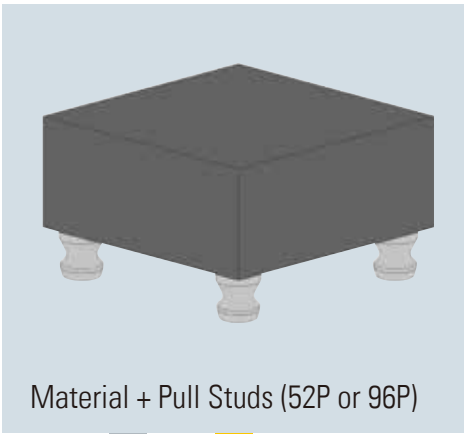
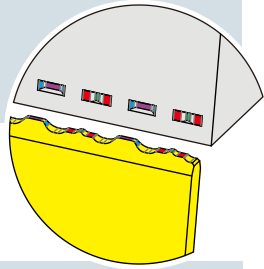
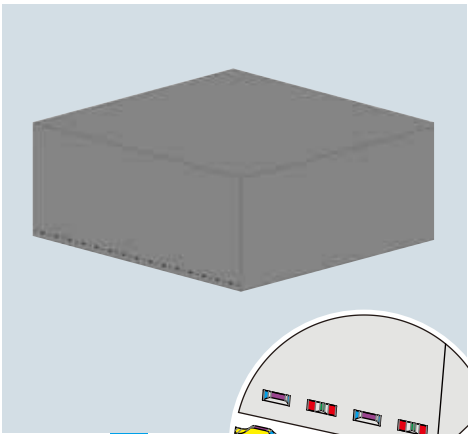

Material + Pull Studs (52P or 96P)

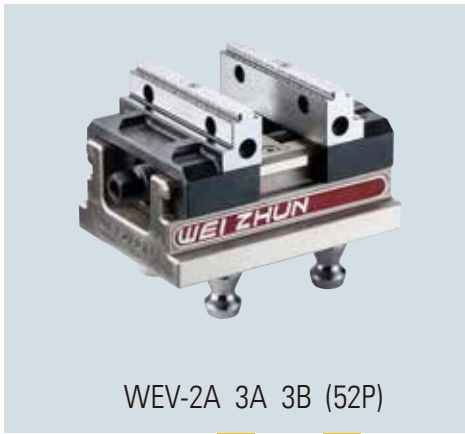

WEV-2A 3A 3B (52P)



WEV-5A 5B 5C (96P)

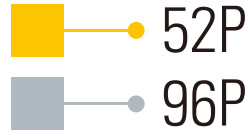

WE-280000 (52P to 96P)



WE-270300 (52P)



WE-260500 (96P)



WE-320500 (96P)



WE-310500 (96P)

Origin Clamp System

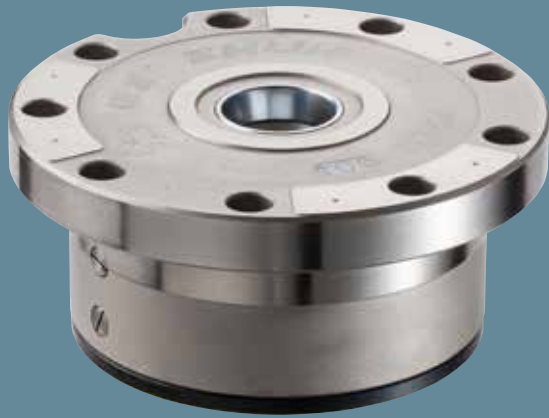

Technical Data	Dimensions	Chuck Clamping	Chuck Opens	
		Power	With	Set/Kg
WE-211050	Ø105x60H	20000N	6-10 Bar	3.7

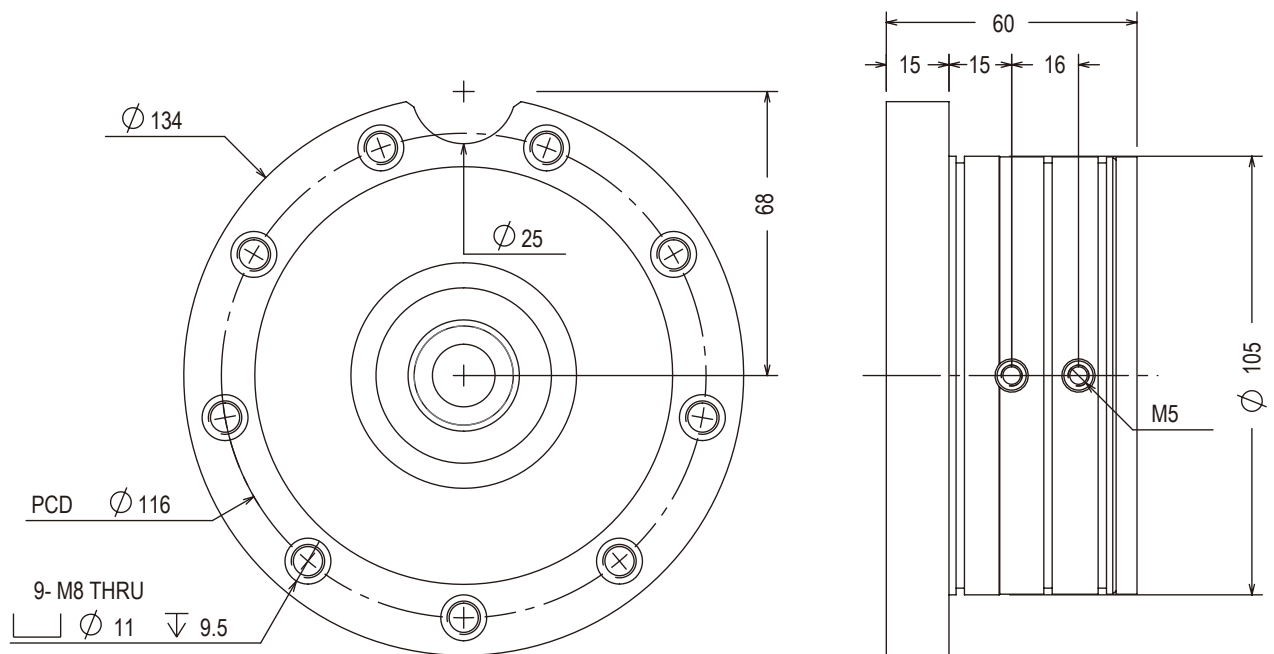

Accessories
WE-201502
1 set of 1

Origin Clamp System



Technical Data	Dimensions	Chuck Clamping	Chuck Opens	
		Power	With	Set/Kg
WE-221550	Ø155x76H	20000N	6-10 Bar	5.5

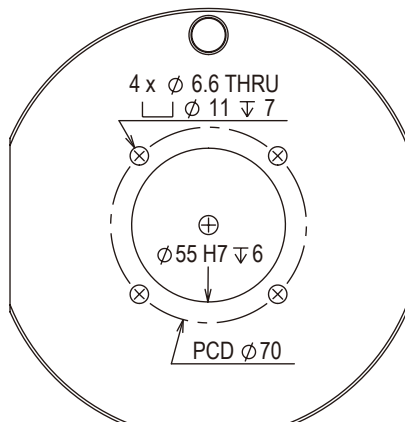
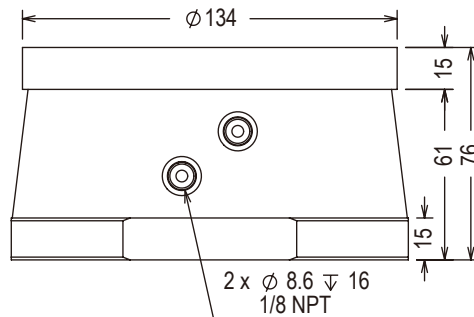
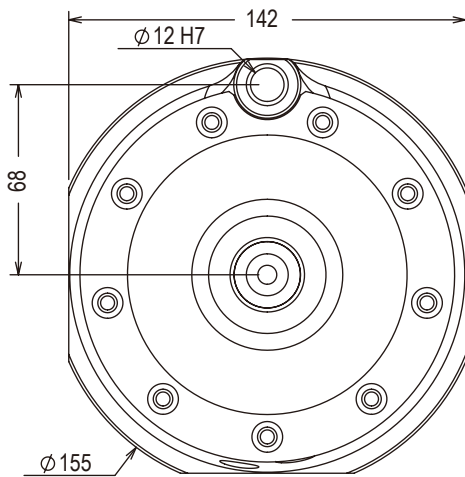

Accessories
WE-201502
1 set of 1

Origin Clamp System

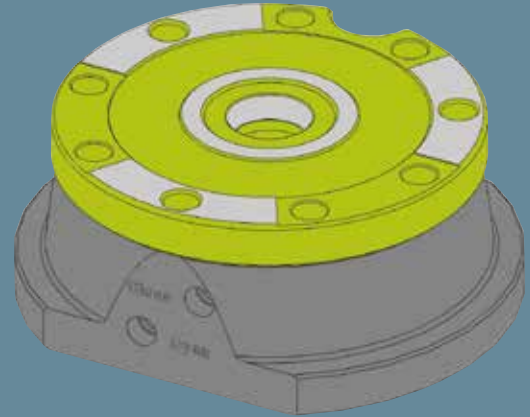
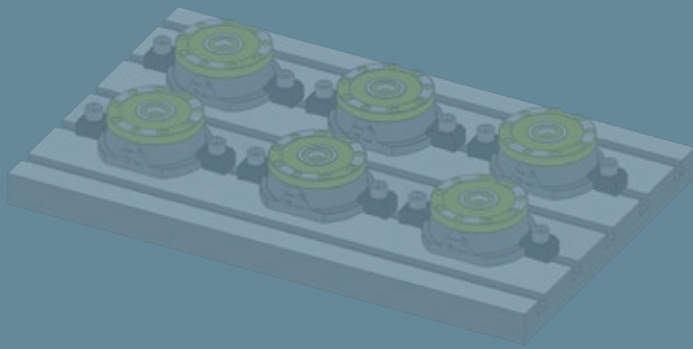

Technical Data	Dimensions	Chuck Clamping		Chuck Opens	
		Power	With	Set/Kg	

WE-221570	Ø157x62H	20000N	6-10 Bar	6.1	
-----------	----------	--------	----------	-----	--

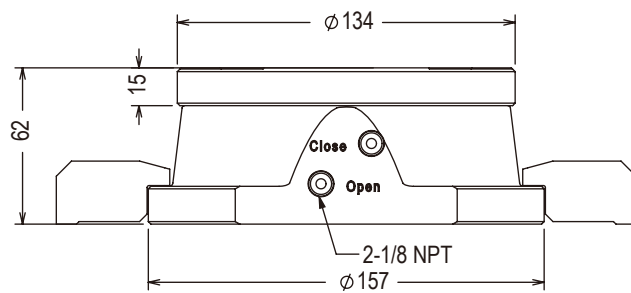
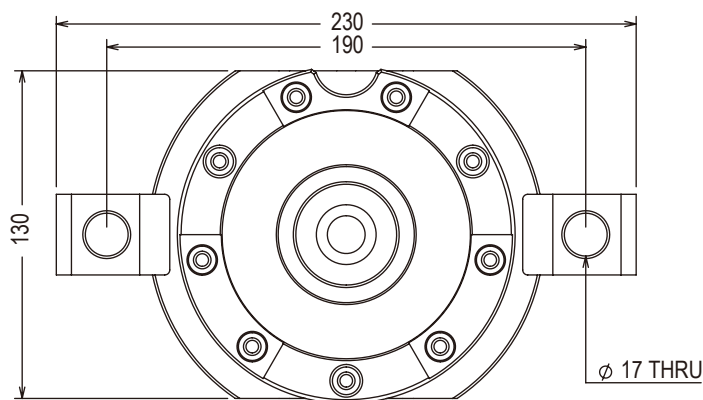

Optional Accessories	
WE201502	WE-3225
1 set of 1	1 set of 2

Origin Clamp System

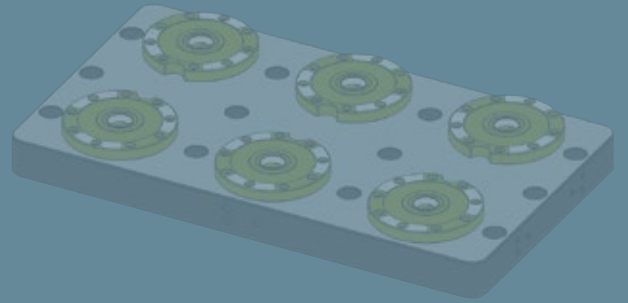
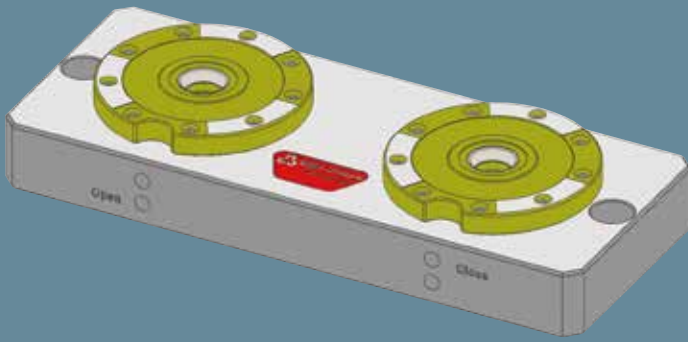

Technical Data	Dimensions	Repeatability	Chuck Clamping Power	Chuck Opens With	Set/Kg
WE-242000	160x400x62mm	0.005	40000N / 2 chuck	6-10 Bar	24.0

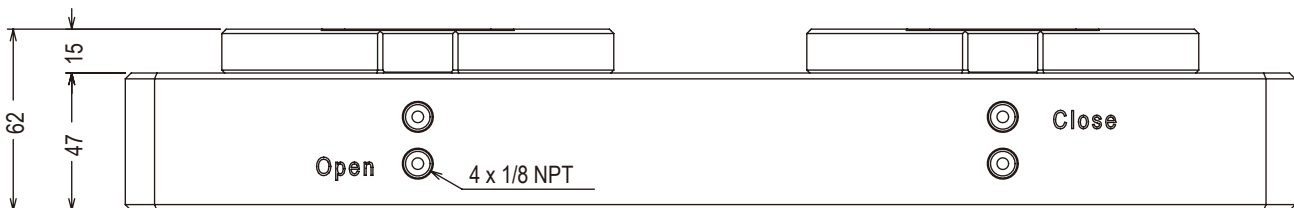
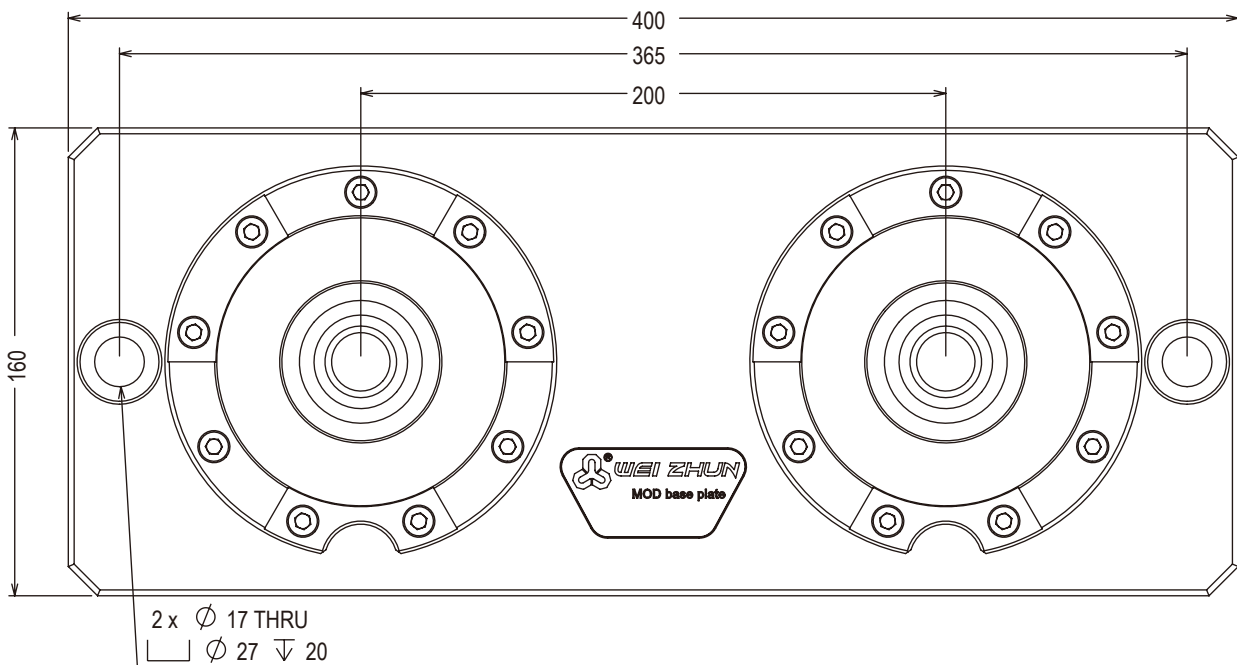

Accessories
WE-201502
1 set of 2

Origin Clamp System



	Technical Data	Dimensions	Repeatability	Chuck Clamping Power	Chuck Opens With	Set/Kg
MOD Base Plate	WE-240000	180x385x62mm	0.005	40000N / 2 chuck	6-10 Bar	18.1

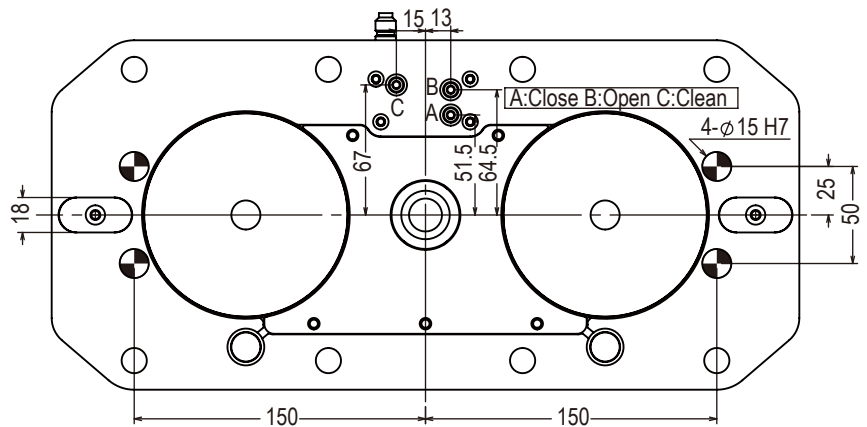
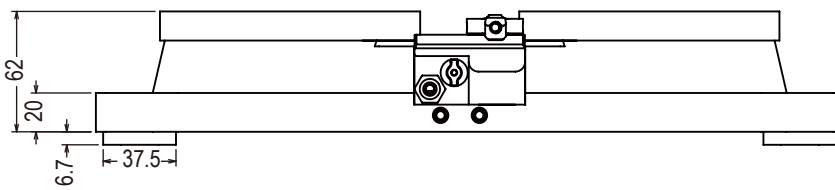
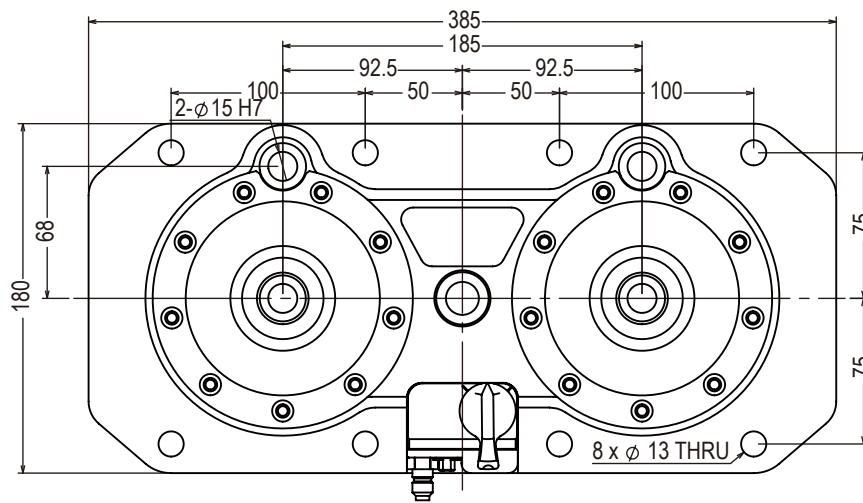

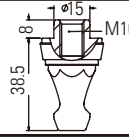
Accessories
WE-201502

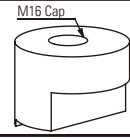
1 set of 2

Attachment
WE-5037

1 set of 2

Origin Clamp System

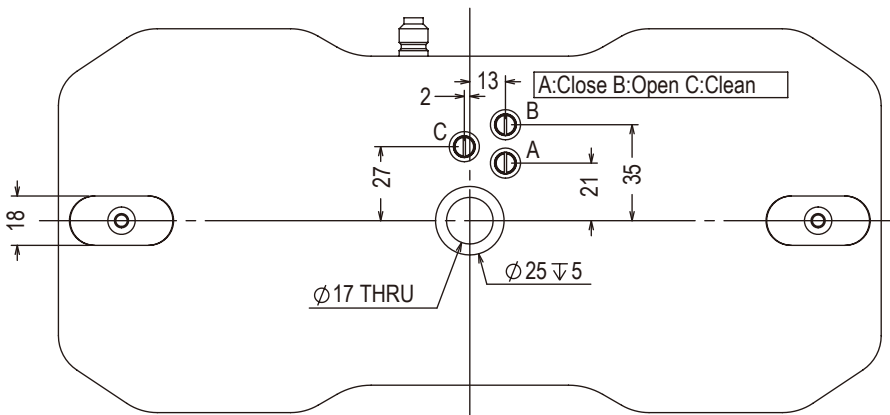
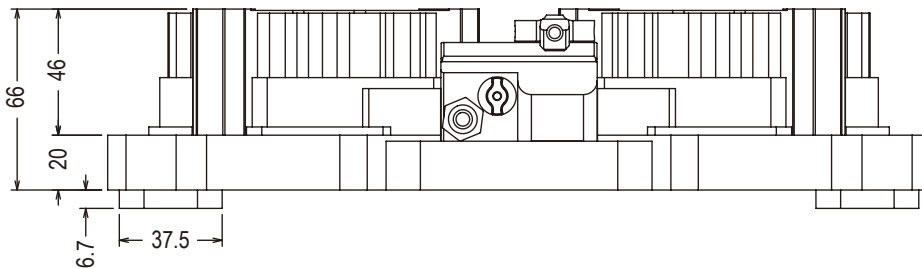
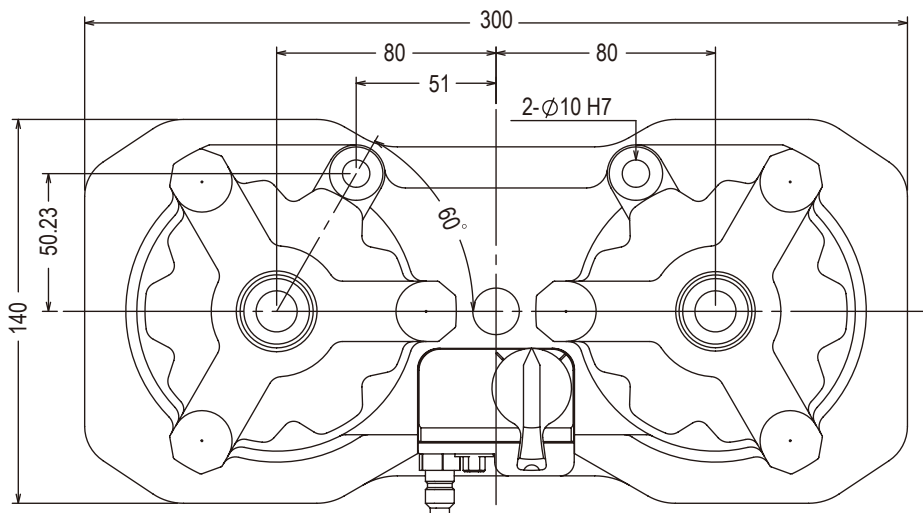

	Technical Data	Dimensions	Repeatability	Chuck Clamping Power	Chuck Opens With	Set/Kg
MOD Base Plate	WE-230000	140x300x66mm	0.005	40000N / 2 chuck	6-10 Bar	12.0



Attachment
WE-5037
M16 Cap
1 set of 2

Accessories
WE-201502
1 set of 2

Machine Arm Chuck

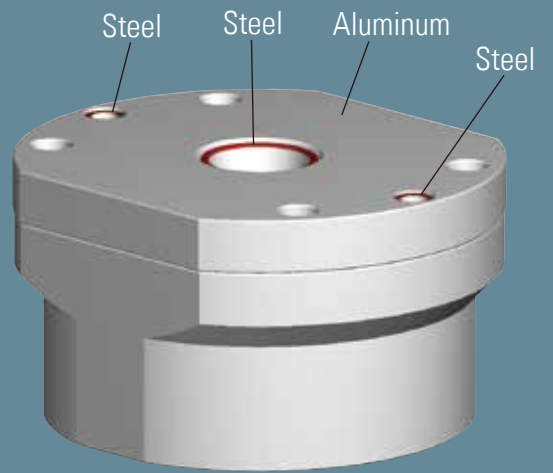

Technical Data	Dimensions	Chuck Clamping	Chuck Opens	Set/Kg
		Power	With	
WE-290000	Ø135x75H	15000N Chuck	6-10 Bar	2.2

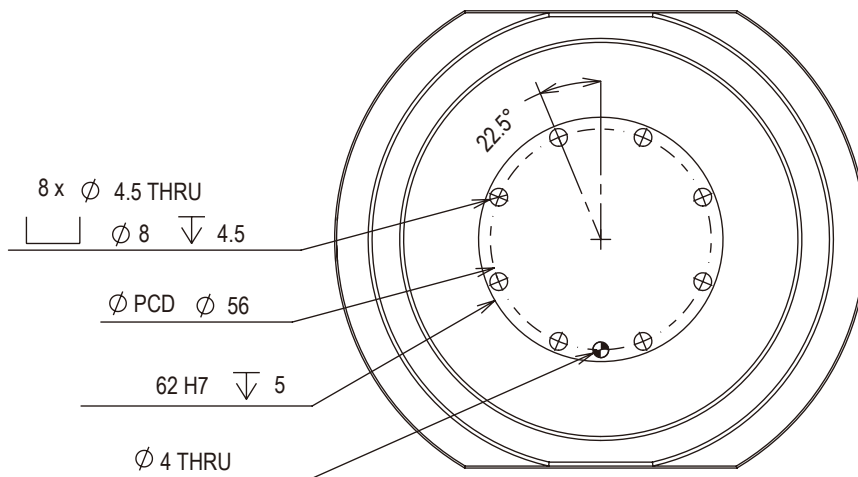
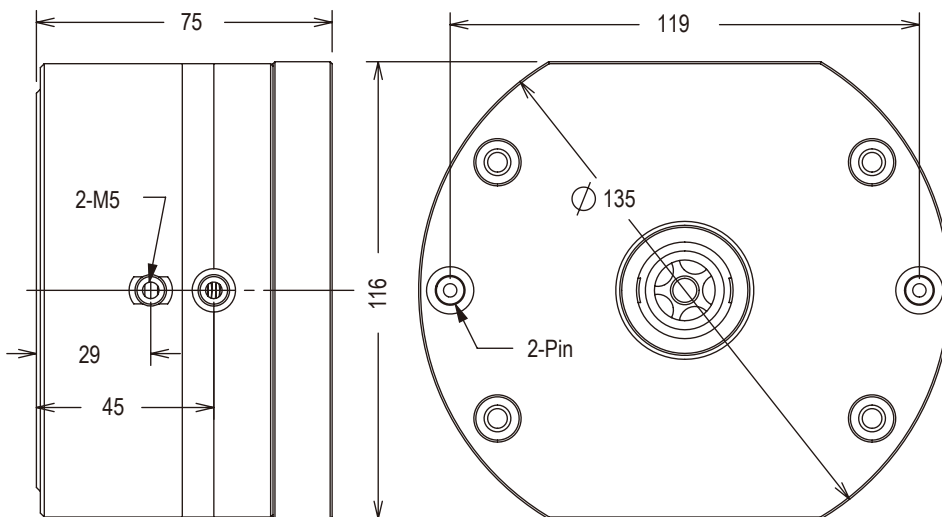

Machine Arm Collet Accessories

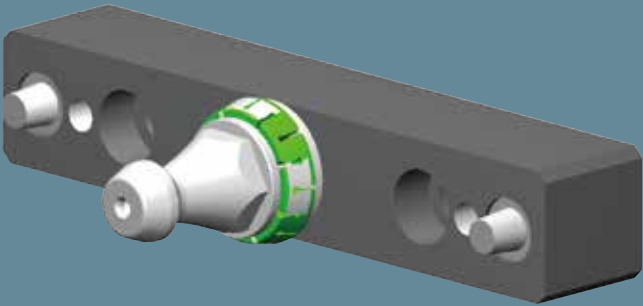

Technical Data	Dimensions	Material	Set/Kg
WE-292500	25x25x138mm	S50C	0.7

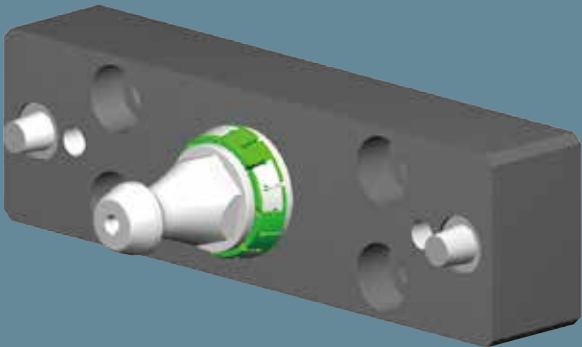
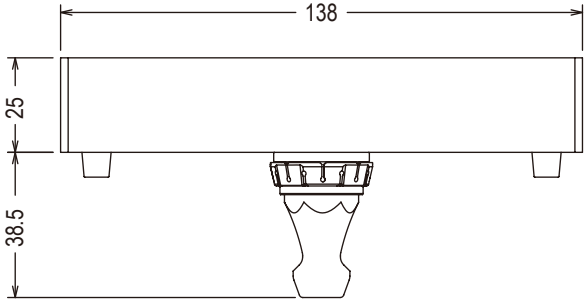
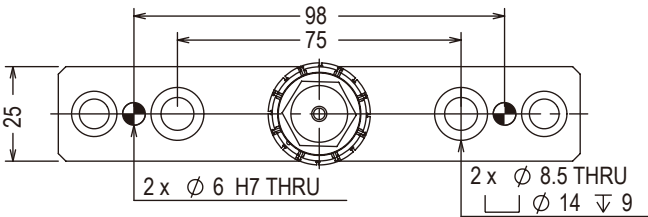

Technical Data	Dimensions	Material	Set/Kg
WE-294000	25x40x138mm	S50C	1.1

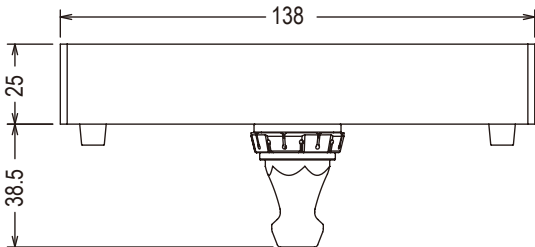
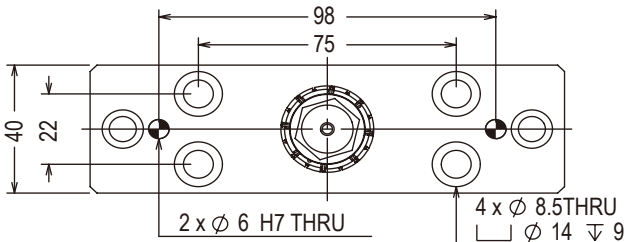



www.softjaws.com.tw



WEI ZHUN ENTERPRISE CO.,LTD.

No.16-3, 2nd Neighborhood, Xinfu, Yuanli Township,
Miaoli County 35865, Taiwan (R.O.C.)
Sales Tel : +886-4-26763867 , +886-985-606082 Fax : +886-4-26887985
Factory Tel : +886-37-867189 Fax : +886-37-851588
E-mail : info@softjaws.com.tw